

Instructions Manual

Tektronix

**DMM912, 914, and 916
Digital Multimeters**

070-9851-01

Table of Contents

DMM912, 914, and 916 Digital Multimeters	1
DMM912, 914, and 916 Specifications	3
DMM912, 914, and 916 Performance Verification	9
Test Equipment	10
Set Up	11
Verification Procedure	12
DMM912 Test Record	19
DMM914 Test Record	23
DMM916 Test Record	29
DMM912, 914, and 916 Adjustment Procedures	35
List of Adjustments	35
Test Equipment	36
Preparation for Adjustment	36
Adjustments Part 1	38
Adjustments Part 2	41
Reassembling the Multimeter	42

DMM912, 914, and 916 Digital Multimeters

The Tektronix DMM912, DMM914, and DMM916 digital multimeters provide many features. Table 1 lists the features of each meter for easy comparison.

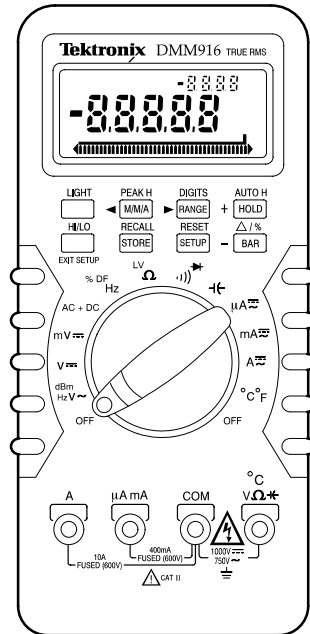

Figure 1: DMM916 Digital Multimeter

Table 1: DMM91X series digital multimeter features

Feature	DMM912	DMM914	DMM916
40,000 display count	•	•	•
Bargraph	•	•	•
Centering and zooming		•	•
True RMS or average AC measurements	•	•	•
Autorange	•	•	•
Measurements			
DC/AC voltage	•	•	•
AC + DC voltage	•	•	•
DC/AC current	•	•	•

Table 1: DMM91X series digital multimeter features (cont.)

Feature	DMM912	DMM914	DMM916
Resistance	•	•	•
Frequency	•	•	•
Diodes and capacitors	•	•	•
Continuity	•	•	•
Duty factor		•	•
Temperature		•	•
Decibel			•
AC volts and amps with Hz display		•	•
Measurement hold	•	•	•
Peak hold			•
Minimum, maximum, and average values	•	•	•
M/M/A time stamp		•	•
Delta mode	•	•	•
HI/LO limits		•	•
Memory store and recall	•	•	•
Backlight			•
Automatic fuse verification	•	•	•
Improper input connection warning	•	•	•

DMM912, 914, and 916 Specifications

The characteristics listed in this section apply under the following conditions:

- The instrument operates in an 18° to 28° C ambient environment at less than 75% relative humidity.
- The batteries are adequately charged (the battery indicator does not display).

NOTE. All specifications are warranted unless marked “typical.” Typical characteristics are not guaranteed but are provided for the convenience of the user.

Table 2: General specifications

Characteristic	Description
LCD display digits	4 ³ / ₄ or 3 ³ / ₄
Bargraph segments	40
Display count	40,000 or 4,000
Numeric update rate	1 time/sec (40,000 count) 4 times/sec (4,000 count)
Bargraph	20 times/sec
Polarity display	Automatic
Overrange display	OL is displayed
Low voltage indicator	Battery indicator
Automatic power-off time	User selectable (default = 15 minutes)
Power source	One 9 V battery, ANSI/NEDA 1604A, IEC 6F22
Maximum input voltage	1000 V (750 V AC) CAT II between V and COM
Maximum floating voltage	1000 V (750 V AC) CAT II between any terminal and earth ground
Maximum input current	400 mA between μ A mA and COM 10 A continuous between A and COM (20 A for 30 seconds)
Maximum open circuit voltage	Current inputs: 600 V between A and COM and between μ A mA and COM
Overload protection	
μ A mA connector	1 A (600 V) fast blow fuse (type BLS or BBS) Tektronix part number 159-0337-00
A connector	15 A (600 V) fast blow fuse (type KTK or KLK) Tektronix part number 159-0287-00
V connector	1100 V _{pk} V \sim V $\overline{\text{---}}$ AC + DC 850 V _{pk} mV $\overline{\text{---}}$ Hz Ω $\overline{\text{---}}$) °C $\overline{\text{---}}$

Table 3: Measurement characteristics

Characteristic	Description			
DC voltage				
V ranges	4 V, 40 V, 400 V, 1000 V			
mV range	400 mV			
Accuracy (% + 10 counts) ¹	<i>DMM912</i>	<i>DMM914</i>	<i>DMM916</i>	
	±0.2%	±0.1%	±0.06%	
AC voltage				
Ranges	4 V, 40 V, 400 V, 750 V			
Accuracy ⁵ (% + 40 counts) ¹	<i>DMM912</i>	<i>DMM914</i>	<i>DMM916</i>	
	50 to 100 Hz	±1.0%	±0.8%	±0.7%
	>100 to 1 kHz ²	±2.5%	±2.0%	±1.5%
	>1 kHz to 10 kHz ²	---	±3.5%	±2.5%
	>10 kHz to 20 kHz ²	---	---	±3.5%
Bandwidth	<i>DMM912</i>	<i>DMM914</i>	<i>DMM916</i>	
	1 kHz	10 kHz	20 kHz	
Crest factor	≤3			
Input impedance	10 MΩ paralleled by 100 pF			
AC + DC volts	Same as AC (RMS) + 1.2% + 10 counts ³			
dBm/dB	dBm reference = 1 mV into 600 Ω			
	dB reference = 1 V			
Current				
AC and DC ranges	4,000 μA, 400 mA, 10 A: 20 A maximum for < 30 seconds			
DC accuracy (% + 10 counts) ¹	<i>DMM912</i>	<i>DMM914</i>	<i>DMM916</i>	
	±0.5%	±0.4%	±0.3%	
AC accuracy (% + 80 counts) ¹	±1.2%	±0.9%	±0.9%	
Bandwidth (typical)	≤1 kHz			
Resistance				
Ranges				
Ω ranges	400 Ω, 4 kΩ, 40 kΩ, 400 kΩ, 4 MΩ, 40 MΩ			
LV ranges	4 kΩ, 40 kΩ, 400 kΩ, 4 MΩ, 40 MΩ			
Accuracy	<i>DMM912</i>	<i>DMM914</i>	<i>DMM916</i>	
	Ω (% + 10 counts) ¹	±0.5%	±0.4%	±0.3%
	LV (% + 1 count) ^{2,3}	±1%	±0.8%	±0.6%
	4 MΩ/400 Ω range	±1%	±0.8%	±0.6%
	40 MΩ range ³	±5%	±5%	±5%

Table 3: Measurement characteristics (cont.)

Characteristic	Description
Compliance voltages (typical)	1 V (Ω setting) 0.4 V (LV setting)
Continuity threshold ³	Beeper sounds when resistance is approximately 75 Ω or less
Diode test ³	
Test current (typical)	0.6 mA
Test voltage (typical)	≤ 3 V
Capacitance	
Ranges	4 nF, 40 nF, 400 nF, 4 μ F, 40 μ F, 400 μ F, 4 mF, 40 mF
Accuracy ³ (% + 10 count)	
4 nF to 4 μ F	$\pm 1\%$ (delta mode)
40 μ F to 40 mF	$\pm 3\%$
Frequency ⁴	
Ranges	400 Hz, 4 kHz, 40 kHz, 400 kHz, 2 MHz
Accuracy ⁶ (% + 10 count)	
400 Hz to 400 kHz	$\pm 0.01\%$
2 MHz	$\pm 0.15\%$
Sensitivity	0.5 V _{p-p}
Duty factor	
Accuracy	$\pm(0.1\% + 0.05\%$ per kHz) for 5 V input
Range	15 Hz to 10 kHz (10% to 90% duty factor)
Temperature	
Range	-50° to $+980^{\circ}$ C
Accuracy	2 $^{\circ}$ C
Thermocouple type	K
Peak measurements ³	
Accuracy	DC volts: $\pm 5\%$ + 40 counts of the peak value of a single 1 ms pulse

¹ Divide counts by 10 in 4000 count mode.

² 750 V, 40 M Ω –LV range unspecified.

³ 4000 count mode only.

⁴ Upper display readout is limited to 10 kHz with reduced accuracy.

⁵ >10% range, 4 V range > 1 V.

⁶ >5% range.

Table 4: Physical characteristics

Characteristic	Description
Dimensions	
Without holster	32 mm × 86 mm × 185 mm (H × W × D)
Weight	
With battery	370 g (13 oz.)
With battery and holster	600 g (21.2 oz.)

Table 5: Environmental characteristic

Characteristic	Description
Temperature	
Operating	0° to +50° C
Nonoperating (storage)	-20° to +60° C
Humidity	
Operating	<80%
Altitude	
Operating	2,000 m (6,562 ft.)
Nonoperating	12,300 m (40354 ft.)
Vibration	
Operating	2.66 g _{RMS} , 5 to 500 Hz, 3 axes (10 minutes each)
Nonoperating	3.48 g _{RMS} , 5 to 500 Hz, 3 axes (10 minutes each)

Table 6: Certifications and compliances

Characteristic	Description
EC Declaration of Conformity	Meets the intent of Directive 89/336/EEC for Electromagnetic Compatibility and Low Voltage Directive 73/23/ECC for Product Safety. Compliance was demonstrated to the following specifications as listed in the official Journal of the European Communities: EN 55011 Class A: Radiated and Conducted Emissions EN 50082-1 Immunity: IEC 801-2 Electrostatic Discharge IEC 801-3 RF Radiated EN 61010-1: Electrical equipment safety requirements for measurement, control, and laboratory use
Certifications	Certified UL3111-1 and CAN/CSA C22.2 No. 1010.1-92

Table 6: Certifications and compliances (cont.)

Characteristic	Description
Overvoltage category	CAT III: Distribution level mains, fixed installation
	CAT II: Local level mains, appliances, portable equipment
	CAT I: Signal level, special equipment or parts of equipment, telecommunication, electronics
Pollution Degree 2	Do not operate in environments where conductive pollutants may be present.

DMM912, 914, and 916 Performance Verification

This section contains procedures to verify that the DMM912, DMM914, and DMM916 Digital Multimeters perform as warranted. If an instrument fails any of these checks, it needs adjustment and or repair.

The performance verification procedures provide a valid confirmation of instrument electrical characteristics and function under the following conditions:

- The multimeter operates in an 18° to 28° C (64° to 82° F) ambient environment with a relative humidity of less than 75%.
- The multimeter stabilizes in the stated ambient temperature for one hour.
- The multimeter warms up for five minutes.
- For AC measurements, allow the multimeter to settle to its final value before taking the measurement.
- The multimeter remains fully assembled and in the holster.

The DMM91X Series performance verification consists of the checks listed in Table 7.

Table 7: Performance verification checks

AC Volts Check
DC Volts Check
DC Millivolts Check
AC+DC Volts Check
Frequency Check
Duty Factor Check (DMM914 and DMM916)
Ω Check
Low Voltage Ω Check
Continuity Check
Diode Check
Capacitance Check
Temperature Check (DMM914 and DMM916)
Volts Peak Hold Check (DMM916)
DC Milliampere Check
AC Milliampere Check
DC Ampere Check
AC Ampere Check

The performance verification procedure should be performed annually or after every 2000 hours of operation if used infrequently.

Test Equipment

The performance verification procedures use external traceable test equipment to directly check warranted characteristics.

Alternative test equipment must meet or exceed the intended minimum requirements listed in Table 8. If you substitute equipment, you may need to modify the procedures.

NOTE. Before beginning the performance verification procedures, warm up the test equipment according to the manufacturer's recommendations.

Table 8: Test equipment

Description	Minimum requirements	Example product
Universal Calibration System	Resolution & accuracy 4 times greater than the multimeter display reading.	Wavetek 9100 with 9105 lead set.
	AC and DC volts measurement ¹ AC and DC current measurement	
	Resistance measurement ¹ Capacitance measurement	
	Sinewave generation Squarewave generation	
Thermocouple adapter	K Type	Tektronix ATK01
Capacitance Standard		Optional

¹ Choose 4-wire measurement setup if available.

Set Up

To prepare for the performance verification checks, do the following steps.

1. Allow the multimeter to stabilize at the ambient temperature for one hour before testing.
2. Turn the multimeter on by rotating the function switch to any position other than OFF.

NOTE. *You need to keep the multimeter powered on throughout the warm-up period and throughout the entire verification procedure.*

Set the auto power off time to a large value or disable the auto power off by pushing the Blue button when turning the dial from the OFF position.

3. Warm up the multimeter for five minutes.
4. Set the Digits to the 40,000 counts display.
5. Pages 19 through 33 contain test records for the DMM91X series multimeters. Each model has its own test record. Photocopy the test record pages for your model to record your test results.

NOTE. *If stability of the display reading causes questionable accuracy of a test, set the multimeter to Average mode.*

Verification Procedure

Implement the following checks to verify the performance of your DMM91X Series multimeter.



WARNING. To avoid electric shock, avoid touching exposed connections.

AC Volts Check

Perform the following steps to verify the AC voltage measurement accuracy.

1. Set the multimeter dial to $V\sim$.
2. Connect the calibrator outputs to the multimeter $^{\circ}C$ V Ω \leftarrow and COM input connectors.
3. Set the calibrator to each of the values in the AC volts test record and verify that the multimeter reads within the specified Display minimum and maximum limits.
4. Turn the calibrator output off.
5. Disconnect the calibrator from the multimeter.

DC Volts Check

Perform the following steps to verify the DC volts measurement accuracy.

1. Set the multimeter dial to $V\equiv$.
2. Connect the calibrator outputs to the multimeter $^{\circ}C$ V Ω \leftarrow and COM input connectors.
3. Set the calibrator to each of the values in the DC volts test record and verify that the multimeter reads within the specified Display minimum and maximum limits.
4. Turn the calibrator output off.
5. Disconnect the calibrator from the multimeter.

DC Millivolts Check

Perform the following steps to verify the DC millivolt measurement accuracy.

1. Set the multimeter dial to $mV\equiv$.
2. Connect the calibrator outputs to the multimeter $^{\circ}C$ V Ω \leftarrow and COM input connectors.
3. Set the calibrator to each of the values in the DC millivolt test record and verify that the multimeter reads within the specified Display minimum and maximum limits.

4. Turn the calibrator output off.
5. Disconnect the calibrator from the multimeter.

AC+DC Volts Check

Perform the following steps to verify the AC+DC voltage measurement accuracy.

1. Set the multimeter dial to AC+DC.
2. Connect the calibrator outputs to the multimeter $^{\circ}\text{C}$ V Ω \leftarrow and COM input connectors.
3. Set the calibrator to each of the values in the AC+DC volts test record and verify that the multimeter reads within the specified Display minimum and maximum limits.
4. Set the calibrator output to OFF.
5. Disconnect the calibrator from the multimeter.

Frequency Check

Perform the following steps to verify the frequency measurement accuracy.

1. Set the multimeter dial to Hz.
2. Connect the calibrator outputs to the multimeter $^{\circ}\text{C}$ V Ω \leftarrow and COM input connectors.
3. Set the calibrator to each of the values in the Frequency test record and verify that the multimeter reads within the specified Display minimum and maximum limits.
4. Turn the calibrator output off.
5. Disconnect the calibrator from the multimeter.

**Duty Factor Check
(DMM914 and DMM916)**

Perform the following steps to verify the duty factor measurement accuracy.

1. Set the multimeter dial to Hz.
2. Push the BLUE button to select duty factor.
3. Connect the calibrator outputs to the multimeter $^{\circ}\text{C}$ V Ω \leftarrow and COM input connectors.
4. Set the calibrator to each of the values in the Duty factor test record and verify that the multimeter reads within the specified Display minimum and maximum limits.

5. Turn the calibrator output off.
6. Disconnect the calibrator from the multimeter.

Ω Check Perform the following steps to verify the resistance measurement accuracy in Ω mode.

1. Set the multimeter dial to Ω .
2. Connect the calibrator outputs to the multimeter $^{\circ}\text{C}$ V Ω \leftarrow and COM input connectors.
3. Set the calibrator to each of the values in the Ω test record and verify that the multimeter reads within the specified Display minimum and maximum limits.
4. Turn the calibrator output off.
5. Disconnect the calibrator from the multimeter.

Low Voltage Ω Check Perform the following steps to verify the resistance measurement accuracy in LV mode.

1. Set the multimeter dial to Ω .
2. Push the BLUE button to select the LV mode.
3. Connect the calibrator outputs to the multimeter $^{\circ}\text{C}$ V Ω \leftarrow and COM input connectors.
4. Set the calibrator to each of the values in the Low voltage Ω test record and verify that the multimeter reads within the specified Display minimum and maximum limits.
5. Turn the calibrator output off.
6. Disconnect the calibrator from the multimeter.

Continuity Check Perform the following steps to verify the continuity check accuracy.

1. Set the multimeter dial to))) .
2. Connect the calibrator outputs to the multimeter $^{\circ}\text{C}$ V Ω \leftarrow and COM input connectors.
3. Set the calibrator to each of the values in the Continuity test record and verify proper operation.
4. Turn the calibrator output off.
5. Disconnect the calibrator from the multimeter.

6. Insert the multimeter test leads into the °C V Ω ← and COM input connectors of the multimeter.
7. Short the test leads together and check for proper operation.

Diode Check

Perform the following steps to verify the diode check accuracy.

1. Set the multimeter dial to >>> .
2. Push the BLUE button to select the diode test mode.
3. Connect the calibrator outputs to the multimeter °C V Ω ← and COM input connectors.
4. Set the calibrator to each of the values in the Diode test record and verify that the multimeter reads within the specified Display minimum and maximum limits.
5. Turn the calibrator output off.
6. Disconnect the calibrator from the multimeter.

Capacitance Check

Perform the following steps to verify the capacitance measurement accuracy.

1. Set the multimeter dial to ←.
2. Set the noise suppression to 60 Hz:
 - a. Press the DMM SETUP key (repeatedly) until the upper display reads 5060.
 - b. Set the main display to 60 Hz with the + and – keys.
3. Null the residual DMM and lead capacitance offset.
 - a. Using Fluke 5500A or Wavetek 9100 minus the 9105 front porch:
 - Turn the calibrator output off.
 - Connect the test leads to the multimeter °C V Ω ← and COM inputs.
 - Connect the multimeter COM lead to the calibrator common output.
 - Press the multimeter gold key followed by the Δ/% key.
 - Connect the multimeter °C V Ω ← lead to the remaining calibrator output.
 - Turn the calibrator output on.

- b. Using Wavetek 9100 with 9105 front porch:
 - Turn the calibrator output off.
 - Connect the multimeter test leads to the calibrator outputs.
 - Connect the calibrator common lead to the multimeter COM input.
 - Press the multimeter gold key followed by the $\Delta/\%$ key.
 - Connect the remaining calibrator output lead to the multimeter $^{\circ}\text{C V } \Omega \leftarrow$ input.
 - Turn the calibrator output on.
4. Set the calibrator to each of the values in the Capacitance test record and verify that the multimeter reads within the specified Display minimum and maximum limits.
5. Turn the calibrator output off.
6. Disconnect the calibrator from the multimeter.

**Temperature Check
(DMM914 and DMM916)**

Perform the following steps to verify the temperature measurement accuracy.

1. Set the multimeter dial to $^{\circ}\text{C} / ^{\circ}\text{F}$.
2. Connect the ATK01 thermocouple adapter to the multimeter $^{\circ}\text{C V } \Omega \leftarrow$ and COM input connectors.
3. Connect the Standard thermocouple (K type) of the calibrator to the ATK01 thermocouple adapter.
4. Allow five minutes for the connector temperature to stabilize.
5. Set the calibrator to each of the values in the Temperature test record and verify that the multimeter reads within the specified Display minimum and maximum limits.
6. Turn the calibrator output off.
7. Disconnect the calibrator from the multimeter.

**Volts Peak Hold Check
(DMM916)**

Perform the following steps to verify the DC volts peak measurement accuracy.

1. Set the multimeter dial to $\text{V} \overline{\text{=}}$.
2. Push the GOLD button and then the M/M/A button to select PEAK H.
3. Connect the calibrator outputs to the multimeter $^{\circ}\text{C V } \Omega \leftarrow$ and COM input connectors.

4. Set the calibrator to each of the values in the Volts peak hold test record and verify that the multimeter reads within the specified Display minimum and maximum limits.
5. Turn the calibrator output off.
6. Disconnect the calibrator from the multimeter.

DC Milliampere Check

Perform the following steps to verify the DC milliampere measurement accuracy.

1. Set the multimeter dial to μA $\overline{\text{A}}$ or mA $\overline{\text{A}}$ as needed.
2. Connect the calibrator outputs to the multimeter μA mA and COM input connectors.
3. Set the calibrator to each of the values in the DC milliampere test record and verify that the multimeter reads within the specified Display minimum and maximum limits.
4. Turn the calibrator output off.
5. Disconnect the calibrator from the multimeter.

AC Milliampere Check

Perform the following steps to verify the AC milliampere measurement accuracy.

1. Set the multimeter dial to μA $\overline{\text{A}}$ or mA $\overline{\text{A}}$ as needed.
2. Push the BLUE button to select AC mode.
3. Connect the calibrator outputs to the multimeter μA mA and COM input connectors.
4. Set the calibrator to each of the values in the AC milliampere test record and verify that the multimeter reads within the specified Display minimum and maximum limits.
5. Turn the calibrator output off.
6. Disconnect the calibrator from the multimeter.

DC Ampere Check

Perform the following steps to verify the DC ampere measurement accuracy.

1. Set the multimeter dial to A $\overline{\text{A}}$.
2. Connect the calibrator outputs to the multimeter A and COM input connectors.
3. Set the calibrator to each of the values in the DC ampere test record and verify that the multimeter reads within the specified Display minimum and maximum limits.

4. Turn the calibrator output off.
5. Disconnect the calibrator from the multimeter.

AC Ampere Check

Perform the following steps to verify the AC ampere measurement accuracy.

1. Set the multimeter dial to A $\overline{\approx}$.
2. Push the BLUE button to select AC mode.
3. Connect the calibrator outputs to the multimeter A and COM input connectors.
4. Set the calibrator to each of the values in the AC ampere test record and verify that the multimeter reads within the specified Display minimum and maximum limits.
5. Turn the calibrator output off.
6. Disconnect the calibrator from the multimeter.

DMM912 Test Record

Serial number	Procedure performed by	Date

DMM912 test record

Test input	Tolerance	Display minimum	Reading	Display maximum
AC volts test^{1,2}				
3.6000 V	60 Hz	$\pm 1.0\% + 40$ counts	3.5600 V	3.6400 V
	1 kHz	$\pm 2.5\% + 40$ counts	3.5060 V	3.6940 V
36.000 V	60 Hz	$\pm 1.0\% + 40$ counts	35.600 V	36.400 V
	1 kHz	$\pm 2.5\% + 40$ counts	35.060 V	36.940 V
360.00 V	60 Hz	$\pm 1.0\% + 40$ counts	356.00 V	364.00 V
	1 kHz	$\pm 2.5\% + 40$ counts	350.60 V	369.40 V
750.0 V ³	60 Hz	$\pm 1.0\% + 40$ counts	738.5 V	761.5 V

¹ Verify proper DMM range (5 display digits); use manual range if necessary. The 750 V range displays 4 digits.

² The upper display readout is ± 2 counts corresponding to the input frequency.

³ 750 V range not specified above 100 Hz.

DC volts test

0.0000 V	$\pm 0.2\% + 10$ counts	-0.0010 V	0.0010 V
3.6000 V	$\pm 0.2\% + 10$ counts	3.5918 V	3.6082 V
-3.6000 V	$\pm 0.2\% + 10$ counts	-3.6082 V	-3.5918 V
36.000 V	$\pm 0.2\% + 10$ counts	35.918 V	36.082 V
360.00 V	$\pm 0.2\% + 10$ counts	359.18 V	360.82 V
1000.0 V	$\pm 0.2\% + 10$ counts	997.0 V	1003.0 V
-1000.0 V	$\pm 0.2\% + 10$ counts	-1003.0 V	-997.0 V

DC millivolts test

0.00 mV	$\pm 0.2\% + 10$ counts	-0.10 mV	0.10 mV
40.00 mV	$\pm 0.2\% + 10$ counts	39.82 mV	40.18 mV
360.00 mV	$\pm 0.2\% + 10$ counts	359.18 mV	360.82 mV
-360.00 mV	$\pm 0.2\% + 10$ counts	-360.82 mV	-359.18 mV

DMM912 test record (cont.)

Test input		Tolerance	Display minimum	Reading	Display maximum
AC+DC volts test¹					
-1.000 V	DC	±2.2% +14 counts	0.964 V		1.036 V
1.000 V	DC	±2.2% +14 counts	0.964 V		1.036 V
1.000 V	60 Hz	±2.2% +14 counts	0.964 V		1.036 V

¹ 4000 count mode only.

Frequency test

20.00 Hz ¹	1 V _{p-p}	±0.01% + 10 counts	19.90 Hz		20.10 Hz
100.00 Hz ¹	1 V _{p-p}	±0.01% + 10 counts	99.89 Hz		100.11 Hz
1.0000 kHz ¹	1 V _{p-p}	±0.01% + 10 counts	.9989 kHz		1.0011 kHz
10.000 kHz ¹	1 V _{p-p}	±0.01% + 10 counts	9.989 kHz		10.011 kHz
100.00 kHz ¹	1 V _{p-p}	±0.01% + 10 counts	99.89 kHz		100.11 kHz
1.0000 MHz ^{1,2}	1 V _{p-p}	±0.15% + 10 counts	0.9975 MHz		1.0025 MHz

¹ Select Frequency mode if using the Wavetek 9100; set the amplitude to 1 V. Select the square wave AC mode if using the Fluke 5500A; set the amplitude to 1.000 V.

² Select the sine wave AC mode if using the Fluke 5500A; set the amplitude to 0.354 V.

Ω test

0.00 Ω ¹	±0.5% + 10 counts	-0.10 Ω		0.10 Ω
360.00 Ω ¹	±1% + 10 counts	356.30 Ω		363.70 Ω
3.6000 kΩ	±0.5% + 10 counts	3.5810 kΩ		3.6190 kΩ
36.000 kΩ	±0.5% + 10 counts	35.810 kΩ		36.190 kΩ
360.00 kΩ	±0.5% + 10 counts	358.10 kΩ		361.90 kΩ
3.6000 MΩ	±1% + 10 counts	3.5630 MΩ		3.6370 MΩ
20.00 MΩ ²	±5% + 10 counts	18.90 MΩ		21.10 MΩ

¹ To test these values with the Fluke 5500A, apply 0.0 Ω and set the DMM to Delta mode.

² 4,000 count mode only.

DMM912 test record (cont.)

Test input	Tolerance	Display minimum	Reading	Display maximum
Low voltage Ω test¹				
3.600 k Ω ²	$\pm 1\% + 1$ count	3.563 k Ω		3.637 k Ω
36.00 k Ω	$\pm 1\% + 1$ count	35.63 k Ω		36.37 k Ω
360.0 k Ω	$\pm 1\% + 1$ count	356.3 k Ω		363.7 k Ω
3.600 M Ω	$\pm 1\% + 1$ count	3.563 M Ω		3.637 M Ω

¹ 4000 count mode only.

² Use DMM manual ranging or set calibrator to 3.0 k Ω before selecting 3.6k Ω .

Continuity test

0.0 Ω	–	Beeper sounds		
150 Ω	–	Beeper does not sound		
Multimeter leads shorted	–	Beeper sounds		

Diode test

0.5 V	–	0.400 V		0.600 V
-------	---	---------	--	---------

Capacitance test^{1,2}

3.600 nF	$\pm 1\% + 10$ counts	3.554 nF		3.646 nF
36.00 nF	$\pm 1\% + 10$ counts	35.54 nF		36.46 nF
360.0 nF	$\pm 1\% + 10$ counts	355.4 nF		364.6 nF
3.600 μ F	$\pm 1\% + 10$ counts	3.554 μ F		3.646 μ F
36.00 μ F	$\pm 3\% + 10$ counts	34.82 μ F		37.18 μ F
360.0 μ F ³	$\pm 3\% + 10$ counts	348.2 μ F		371.8 μ F
3.600 mF ³	$\pm 3\% + 10$ counts	3.482 mF		3.718 mF
36.00 mF ³	$\pm 3\% + 10$ counts	34.82 mF		37.18 mF

¹ Variations in test equipment can cause erroneous readings. Use a fixed value capacitance standard if instability occurs.

² Set the DMM to Delta mode. Delta mode removes stray capacitance for low capacitance measurements.

³ Set the DMM noise suppression to 60 Hz with the SETUP mode. See Page 15 for detailed instructions.

DMM912 test record (cont.)

Test input	Tolerance	Display minimum	Reading	Display maximum
DC milliampere test				
0.0 μ A	± 10 counts	-1.0 μ A		1.0 μ A
360.0 μ A	$\pm 0.5\% + 10$ counts	357.2 μ A		362.8 μ A
-360.0 μ A	$\pm 0.5\% + 10$ counts	-362.8 μ A		-357.2 μ A
3600.0 μ A	$\pm 0.5\% + 10$ counts	3581.0 μ A		3619.0 μ A
36.00 mA	$\pm 0.5\% + 10$ counts	35.72 mA		36.28 mA
360.00 mA	$\pm 0.5\% + 10$ counts	358.10 mA		361.90 mA

AC milliampere test (60 Hz)

3600.0 μ A	$\pm 1.2\% + 80$ counts	3548.8 μ A		3651.2 μ A
360.00 mA	$\pm 1.2\% + 80$ counts	354.88 mA		365.12 mA

DC ampere test

10.000 A	0.5% + 10 counts	9.940 A		10.060 A
----------	------------------	---------	--	----------

AC ampere test (60 Hz)

10.000 A	$\pm 1.2\% + 80$ counts	9.800 A		10.200 A
----------	-------------------------	---------	--	----------

DMM914 Test Record

Serial number	Procedure performed by	Date

DMM914 test record

Test input	Tolerance	Display minimum	Reading	Display maximum
AC volts test^{1,2}				
3.6000 V	60 Hz	$\pm 0.8\% + 40$ counts	3.5672 V	3.6328 V
	500 Hz	$\pm 2.0\% + 40$ counts	3.5240 V	3.6760 V
	10 kHz	$\pm 3.5\% + 40$ counts	3.4700 V	3.7300 V
36.000 V	500 Hz	$\pm 2.0\% + 40$ counts	35.240 V	36.760 V
	10 kHz	$\pm 3.5\% + 40$ counts	34.700 V	37.300 V
360.00 V	500 Hz	$\pm 2.0\% + 40$ counts	352.40 V	367.60 V
	10 kHz	$\pm 3.5\% + 40$ counts	347.00 V	373.00 V
750.0 V ³	60 Hz	$\pm 0.8\% + 40$ counts	740.0 V	760.0 V

¹ Verify the proper DMM range (5 display digits); use the manual range if necessary. The 750 V range displays 4 digits.

² The upper display readout is ± 2 counts corresponding to the input frequency.

³ 750 V range not specified above 100 Hz.

DC volts test

0.0000 V	$\pm 0.1\% + 10$ counts	-0.0010 V	0.0010 V
3.6000 V	$\pm 0.1\% + 10$ counts	3.5954 V	3.6046 V
-3.6000 V	$\pm 0.1\% + 10$ counts	-3.6046 V	-3.5954 V
36.000 V	$\pm 0.1\% + 10$ counts	35.954 V	36.046 V
360.00 V	$\pm 0.1\% + 10$ counts	359.54 V	360.46 V
1000.0 V	$\pm 0.1\% + 10$ counts	998.0 V	1002.0 V
-1000.0 V	$\pm 0.1\% + 10$ counts	-1002.0 V	-998.0 V

DMM914 test record (cont.)

Test input	Tolerance	Display minimum	Reading	Display maximum
DC millivolts test				
0.00 mV	$\pm 0.1\% + 10$ counts	-0.10 mV		0.10 mV
40.00 mV	$\pm 0.1\% + 10$ counts	39.86 mV		40.14 mV
360.00 mV	$\pm 0.1\% + 10$ counts	359.54 mV		360.46 mV
-360.00 mV	$\pm 0.1\% + 10$ counts	-360.46 mV		-359.54 mV

AC+DC volts test¹

-1.000 V	DC	$\pm 2.0\% + 14$ counts	0.966 V		1.034 V
1.000 V	DC	$\pm 2.0\% + 14$ counts	0.966 V		1.034 V
1.000 V	60 Hz	$\pm 2.0\% + 14$ counts	0.966 V		1.034 V

¹ 4000 count mode only.

Frequency test

20.00 Hz ¹	1 V _{p-p}	$\pm 0.01\% + 10$ counts	19.90 Hz		20.10 Hz
100.00 Hz ¹	1 V _{p-p}	$\pm 0.01\% + 10$ counts	99.89 Hz		100.11 Hz
1.0000 kHz ¹	1 V _{p-p}	$\pm 0.01\% + 10$ counts	.9989 kHz		1.0011 kHz
10.000 kHz ¹	1 V _{p-p}	$\pm 0.01\% + 10$ counts	9.989 kHz		10.011 kHz
100.00 kHz ¹	1 V _{p-p}	$\pm 0.01\% + 10$ counts	99.89 kHz		100.11 kHz
1.0000 MHz ^{1,2}	1 V _{p-p}	$\pm 0.15\% + 10$ counts	0.9975 MHz		1.0025 MHz

¹ Select Frequency mode if using the Wavetek 9100; set the amplitude to 1 V. Select the square wave AC mode if using the Fluke 5500A; set the amplitude to 1.000 V.

² Select the sine wave AC mode if using the Fluke 5500A; set the amplitude to 0.354 V.

Duty factor test

50.0	5 V, 1 kHz squarewave	$\pm 0.15\%$	49.9		50.1
90.0	5 V, 1 kHz squarewave	$\pm 0.15\%$	89.9		90.1
10.0	5 V, 1 kHz squarewave	$\pm 0.15\%$	9.9		10.1

DMM914 test record (cont.)

Test input	Tolerance	Display minimum	Reading	Display maximum
Ω test				
0.0000 Ω ¹	±0.4% + 10 counts	-0.1000 Ω		0.1000 Ω
360.00 Ω ¹	±0.8% + 10 counts	357.02 Ω		362.98 Ω
3.6000 kΩ	±0.4% + 10 counts	3.5846 kΩ		3.6154 kΩ
36.000 kΩ	±0.4% + 10 counts	35.846 kΩ		36.154 kΩ
360.00 kΩ	±0.4% + 10 counts	358.46 kΩ		361.54 kΩ
3.6000 MΩ	±0.8% + 10 counts	3.5702 MΩ		3.6298 MΩ
20.00 MΩ ²	±5% + 10 counts	18.90 MΩ		21.10 MΩ

¹ To test these values with the Fluke 5500A, apply 0.0 Ω and set the DMM to Delta mode.

² 4,000 count mode only.

Low voltage Ω test¹

3.600 kΩ ²	±0.8% + 1 count	3.570 kΩ		3.630 kΩ
36.00 kΩ	±0.8% + 1 count	35.70 kΩ		36.30 kΩ
360.0 kΩ	±0.8% + 1 count	357.0 kΩ		363.0 kΩ
3.600 MΩ	±0.8% + 1 count	3.570 MΩ		3.630 MΩ

¹ 4000 count mode only.

² Use DMM manual ranging or set calibrator to 3.0 kΩ before selecting 3.6k Ω.

Continuity test

0.0 Ω	-	Beeper sounds		
150 Ω	-	Beeper does not sound		
Multimeter leads shorted	-	Beeper sounds		

Diode test

0.5 V	-	0.400 V		0.600 V
-------	---	---------	--	---------

DMM914 test record (cont.)

Test input	Tolerance	Display minimum	Reading	Display maximum
Capacitance test^{1,2}				
3.600 nF	±1% + 10 counts	3.554 nF		3.646 nF
36.00 nF	±1% + 10 counts	35.54 nF		36.46 nF
360.0 nF	±1% + 10 counts	355.4 nF		364.6 nF
3.600 µF	±1% + 10 counts	3.554 µF		3.646 µF
36.00 µF	±3% + 10 counts	34.82 µF		37.18 µF
360.00 µF ³	±3% + 10 counts	348.2 µF		371.8 µF
3.600 mF ³	±3% + 10 counts	3.482 mF		3.718 mF
36.00 mF ³	±3% + 10 counts	34.82 mF		37.18 mF

¹ Variations in test equipment can cause erroneous readings. Use a fixed value capacitance standard if instability occurs.

² Set the DMM to Delta mode. Delta mode removes stray capacitance for low capacitance measurements.

³ Set the DMM noise suppression to 60 Hz with the SETUP mode. See Page 15 for detailed instructions.

Temperature test

0.0° C	±2° C	-2.0		2.0
-40.0° C	±2° C	-42.0		-38.0
100.0° C	±2° C	98.0		102.0
950.0° C	±2° C	948.0		952.0

DC milliampere test

0.0 µA	±10 counts	-1.0 µA		1.0 µA
360.0 µA	±0.4% + 10 counts	357.6 µA		362.4 µA
-360.0 µA	±0.4% + 10 counts	-362.4 µA		-357.6 µA
3600.0 µA	±0.4% + 10 counts	3584.6 µA		3615.4 µA
36.00 mA	±0.4% + 10 counts	35.76 mA		36.24 mA
360.00 mA	±0.4% + 10 counts	358.46 mA		361.54 mA

DMM914 test record (cont.)

Test input	Tolerance	Display minimum	Reading	Display maximum
AC milliampere test (60 Hz)¹				
3600.0 μ A	$\pm 0.9\% + 80$ counts	3559.6 μ A		3640.4 μ A
360.00 mA	$\pm 0.9\% + 80$ counts	355.96 mA		364.04 mA

¹ The upper display readout is 60 Hz ± 2 counts corresponding to the input frequency.

DC ampere test

10.000 A	$\pm 0.4\% + 10$ counts	9.950 A		10.050 A
----------	-------------------------	---------	--	----------

AC ampere test (60 Hz)¹

10.000 A	$\pm 0.9\% + 80$ counts	9.830 A		10.170 A
----------	-------------------------	---------	--	----------

¹ The upper display readout is 60 Hz ± 2 counts corresponding to the input frequency.

DMM916 Test Record

Serial number	Procedure performed by	Date

DMM916 test record

Test input	Tolerance	Display minimum	Reading	Display maximum
AC volts test^{1,2}				
3.6000 V	60 Hz	$\pm 0.7\% + 40$ counts	3.5708 V	3.6292 V
	500 Hz	$\pm 1.5\% + 40$ counts	3.5420 V	3.6580 V
	10 kHz	$\pm 2.5\% + 40$ counts	3.5060 V	3.6940 V
36.000 V	500 Hz	$\pm 1.5\% + 40$ counts	35.420 V	36.580 V
	10 kHz	$\pm 2.5\% + 40$ counts	35.060 V	36.940 V
360.00 V	500 Hz	$\pm 1.5\% + 40$ counts	354.20 V	365.80 V
	10 kHz	$\pm 2.5\% + 40$ counts	350.60 V	369.40 V
750.0 V ³	60 Hz	$\pm 0.7\% + 40$ counts	740.7 V	759.3V

¹ Verify the proper DMM range (5 display digits); use the manual range if necessary. The 750 V range displays 4 digits.

² The upper display readout is ± 2 counts corresponding to the input frequency.

³ 750 V range not specified above 100 Hz.

DC volts test

0.0000 V	$\pm 0.06\% + 10$ counts	-0.0010 V	0.0010 V
3.6000 V	$\pm 0.06\% + 10$ counts	3.5969 V	3.6031 V
-3.6000 V	$\pm 0.06\% + 10$ counts	-3.6031 V	-3.5969 V
36.000 V	$\pm 0.06\% + 10$ counts	35.969 V	36.031 V
360.00 V	$\pm 0.06\% + 10$ counts	359.69 V	360.31 V
1000.0 V	$\pm 0.06\% + 10$ counts	998.4 V	1001.6 V
-1000.0 V	$\pm 0.06\% + 10$ counts	-1001.6 V	-998.4 V

DMM916 test record (cont.)

Test input	Tolerance	Display minimum	Reading	Display maximum
DC millivolts test				
0.00 mV	±0.06% + 10 counts	-0.10 mV		0.10 mV
40.00 mV	±0.06% + 10 counts	39.88 mV		40.12 mV
360.00 mV	±0.06% + 10 counts	359.69 mV		360.31 mV
-360.00 mV	±0.06% + 10 counts	-360.31 mV		-359.69 mV

AC+DC volts test¹

-1.000 V	DC	±1.9% +14 counts	0.967 V		1.033 V
1.000 V	DC	±1.9% +14 counts	0.967 V		1.033 V
1.000 V	60 Hz	±1.9% +14 counts	0.967 V		1.033 V

¹ 4000 count mode only.

Frequency test

20.00 Hz ¹	1 V _{p-p}	±0.01% + 10 counts	19.90 Hz		20.10 Hz
100.00 Hz ¹	1 V _{p-p}	±0.01% + 10 counts	99.89 Hz		100.11 Hz
1.0000 kHz ¹	1 V _{p-p}	±0.01% + 10 counts	.9989 kHz		1.0011 kHz
10.000 kHz ¹	1 V _{p-p}	±0.01% + 10 counts	9.989 kHz		10.011 kHz
100.00 kHz ¹	1 V _{p-p}	±0.01% + 10 counts	99.89 kHz		100.11 kHz
1.0000 MHz ^{1,2}	1 V _{p-p}	±0.15% + 10 counts	0.9975 MHz		1.0025 MHz

¹ Select Frequency mode if using the Wavetek 9100; set the amplitude to 1 V. Select the square wave AC mode if using the Fluke 5500A; set the amplitude to 1.000 V.

² Select the sine wave AC mode if using the Fluke 5500A; set the amplitude to 0.354 V.

Duty factor test

50.0	5 V, 1 kHz squarewave	±0.15%	49.9		50.1
90.0	5 V, 1 kHz squarewave	±0.15%	89.9		90.1
10.0	5 V, 1 kHz squarewave	±0.15%	9.9		10.1

DMM916 test record (cont.)

Test input	Tolerance	Display minimum	Reading	Display maximum
Ω test				
0.0000 Ω ¹	±0.3% + 10 counts	-0.1000 Ω		0.1000 Ω
360.00 Ω ¹	±0.6% + 10 counts	357.74 Ω		362.26 Ω
3.6000 kΩ	±0.3% + 10 counts	3.5882 kΩ		3.6118 kΩ
36.000 kΩ	±0.3% + 10 counts	35.882 kΩ		36.118 kΩ
360.00 kΩ	±0.3% + 10 counts	358.82 kΩ		361.18 kΩ
3.6000 MΩ	±0.6% + 10 counts	3.5774 MΩ		3.6226 MΩ
20.00 MΩ ²	±5% + 10 counts	18.90 MΩ		21.10 MΩ

¹ To test these values with the Fluke 5500A, apply 0.0 Ω and set the DMM to Delta mode.

² Verify the DMM is in the 4,000 count mode for this test.

Low voltage Ω test¹

3.600 kΩ ²	±0.6% + 1 count	3.577 kΩ		3.623 kΩ
36.00 kΩ	±0.6% + 1 count	35.77 kΩ		36.23 kΩ
360.0 kΩ	±0.6% + 1 count	357.7 kΩ		362.3 kΩ
3.600 MΩ	±0.6% + 1 count	3.577 MΩ		3.623 MΩ

¹ 4000 count mode only.

² Use DMM manual ranging or set calibrator to 3.0 kΩ before selecting 3.6kΩ.

Continuity test

0.0 Ω	-	Beeper sounds		
150 Ω	-	Beeper does not sound		
Multimeter leads shorted	-	Beeper sounds		

Diode test

0.5 V	-	0.400 V		0.600 V
-------	---	---------	--	---------

DMM916 test record (cont.)

Test input	Tolerance	Display minimum	Reading	Display maximum
Capacitance test^{1,2}				
3.600 nF	±1% + 10 counts	3.554 nF		3.646 nF
36.00 nF	±1% + 10 counts	35.54 nF		36.46 nF
360.0 nF	±1% + 10 counts	355.4 nF		364.6 nF
3.600 µF	±1% + 10 counts	3.554 µF		3.646 µF
36.00 µF	±3% + 10 counts	34.82 µF		37.18 µF
360.00 µF ³	±3% + 10 counts	348.2 µF		371.8 µF
3.600 mF ³	±3% + 10 counts	3.482 mF		3.718 mF
36.00 mF ³	±3% + 10 counts	34.82 mF		37.18 mF

¹ Variations in test equipment can cause erroneous readings. Use a fixed value capacitance standard if instability occurs.

² Set the DMM to Delta mode. Delta mode removes stray capacitance for low capacitance measurements.

³ Set the DMM noise suppression to 60 Hz with the SETUP mode. See Page 15 for detailed instructions.

Temperature test

0.0° C	±2° C	-2.0		2.0
-40.0° C	±2° C	-42.0		-38.0
100.0° C	±2° C	98.0		102.0
950.0° C	±2° C	948.0		952.0

Volts peak hold test

1 V _{RMS} (60 Hz, 1.414 V _p)	MAX	±5% + 40 counts	1.303 V		1.524 V
1 V _{RMS} (60 Hz, 1.414 V _p)	MIN	±5% + 40 counts	-1.524 V		-1.303 V

DC milliampere test

0.0 µA	±10 counts	-1.0 µA		1.0 µA
360.0 µA	±0.3% + 10 counts	358.0 µA		362.0 µA
-360.0 µA	±0.3% + 10 counts	-362.0 µA		-358.0 µA
3600.0 µA	±0.3% + 10 counts	3588.2 µA		3611.8 µA
36.00 mA	±0.3% + 10 counts	35.80 mA		36.20 mA
360.00 mA	±0.3% + 10 counts	358.82 mA		361.18 mA

DMM916 test record (cont.)

Test input	Tolerance	Display minimum	Reading	Display maximum
AC milliampere test (60 Hz)¹				
3600.0 μ A	$\pm 0.9\% + 80$ counts	3559.6 μ A		3640.4 μ A
360.00 mA	$\pm 0.9\% + 80$ counts	355.96 mA		364.04 mA

¹ The upper display readout is 60 Hz ± 2 counts corresponding to the input frequency.

DC ampere test

10.000 A	$\pm 0.3\% + 10$ counts	9.960 A		10.040 A
----------	-------------------------	---------	--	----------

AC ampere test (60 Hz)¹

10.000 A	$\pm 0.9\% + 80$ counts	9.830 A		10.170 A
----------	-------------------------	---------	--	----------

¹ The upper display readout is 60 Hz ± 2 counts corresponding to the input frequency.

DMM912, 914, and 916 Adjustment Procedures

This section contains procedures to adjust DMM912, DMM914, and DMM916 multimeters. Perform these procedures once a year or if the *DMM912*, *DMM914*, and *DMM916 Performance Verification* procedure indicates the need for calibration.

In this section you will find the following information:

- A list of adjustments
- A list of test equipment needed to make the adjustments
- Instructions on how to prepare the instrument for adjustment
- Step-by-step adjustment procedures

The procedures in this section do not verify performance. To confirm that your multimeter meets factory specifications, perform the procedures in the *DMM912*, *DMM914*, and *DMM916 Performance Verification* section.

List of Adjustments

Use the adjustments listed in Table 9 to return DMM91X Series multimeters to factory calibration.

Table 9: DMM91X series adjustments

Adjustments Part 1
DC Volts
AC Volts
Capacitance
Temperature (DMM914 and DMM916)
DC Milliamperes
DC Amperes
Adjustments Part 2
AC Response

Test Equipment

The test equipment listed in Table 8 on page 10 is a complete list of equipment needed for the adjustment procedures. These procedures assume that the test equipment is operating within tolerance.

Alternative test equipment must meet or exceed the intended minimum requirements specified in Table 8. If you substitute equipment, you may need to modify the procedures.

Preparation for Adjustment

The following guidelines apply to all DMM91X Series adjustments:

- Perform all adjustments in a 21° to 25° C ambient environment with a relative humidity of 75% or less.
- Warm up the multimeter for at least 15 minutes.
- Do not alter any setting without reading the entire adjustment procedure first.
- Do not alter a setting unless a performance characteristic cannot be met at the current setting.
- Read the *Safety Summary* at the beginning of this manual.

Open the Meter Case

You must open the multimeter case to access the internal adjustments. Use the following procedure to open the case.

1. Lay the meter face down on a flat work surface that cannot damage the multimeter face.
2. Remove the three screws from the case bottom using a standard Philips-head screwdriver.
3. Gently lift the end of the case bottom at the end opposite from the display. Then lift the end nearest the display until it unsnaps from the case top. See Figure 2 for details.

To reassemble the multimeter following the adjustments, see page 42.

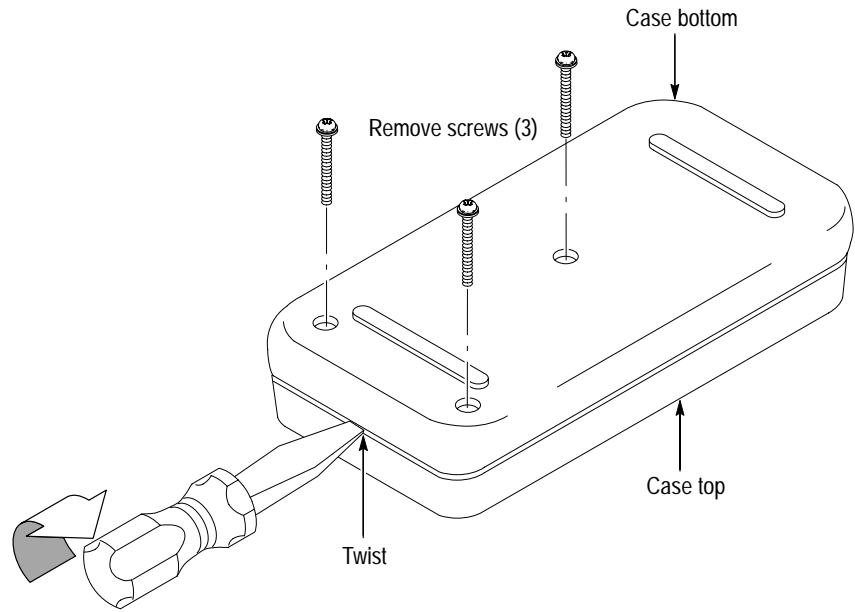

Figure 2: Opening the meter case

Adjustments Part 1

The procedures within this section use the adjustments accessible with the back case removed from the multimeter.

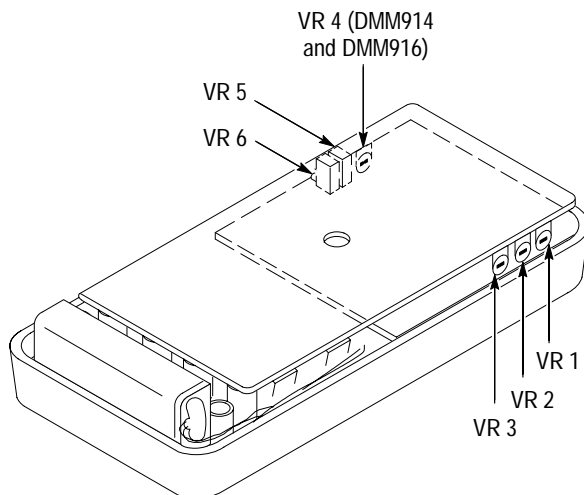

Figure 3: Adjustment locations 1

DC Volts Perform the following steps to adjust the DC voltage calibration.

1. Set the multimeter dial to V_{DC} .
2. Connect the outputs of the calibrator to the V_{DC} and COM input connectors of the multimeter.
3. Set the calibrator to output 3.0000 VDC.
4. Adjust VR5 until the display shows 2.9999 to 3.0001 VDC.
5. Turn the calibrator output off.
6. Disconnect the calibrator from the multimeter.

AC Volts Perform the following steps to adjust the AC voltage calibration at 60 Hz.

1. Set the multimeter dial to V_{AC} .
2. Connect the outputs of the calibrator to the V_{AC} and COM input connectors of the multimeter.
3. Set the calibrator to output 2.0000 VAC at 60 Hz.
4. Adjust VR6 until the display shows 1.9999 to 2.0001 VAC.

5. Turn the calibrator output off.
6. Disconnect the calibrator from the multimeter.

Capacitance

Perform the following steps to adjust the capacitance calibration.

1. Set the multimeter dial to Ω .
2. Null the residual DMM and lead capacitance offset.
 - a. Using Fluke 5500A or Wavetek 9100 minus the 9105 front porch:
 - Turn the calibrator output off.
 - Connect the test leads to the multimeter Ω and COM inputs.
 - Connect the multimeter COM lead to the calibrator common output.
 - Press the multimeter gold key followed by the $\Delta/\%$ key.
 - Connect the multimeter Ω lead to the remaining calibrator output.
 - Turn the calibrator output on.
 - b. Using Wavetek 9100 with 9105 front porch:
 - Turn the calibrator output off.
 - Connect the multimeter test leads to the calibrator outputs.
 - Connect the calibrator common lead to the multimeter COM input.
 - Press the multimeter gold key followed by the $\Delta/\%$ key.
 - Connect the remaining calibrator output lead to the multimeter Ω input.
 - Turn the calibrator output on.
3. Set the calibrator to output 300 nF.
4. Adjust VR2 until the display shows 299.9 to 300.1 nF.
5. Set the calibrator to output 1.000 μ F.
6. Adjust VR3 until the display shows 0.999 to 1.001 μ F.
7. Set the calibrator to output 100.0 μ F.
8. Adjust VR1 until the display shows 99.9 to 100.1 μ F.

9. Turn the calibrator output off.
10. Disconnect the calibrator from the multimeter.

**Temperature
(DMM914 and DMM916)**

Perform the following steps to adjust the temperature calibration.

1. Set the multimeter dial to °C / °F.
2. Connect the thermocouple adapter ATK01 to the °C V Ω μ A and COM input connectors of the multimeter.
3. Set the calibrator to output 18.6° C.
4. Connect a K-type thermocouple from the calibrator output to the ATK01 thermocouple adapter.
5. Allow five minutes of settling time for a stable reading.
6. Adjust VR4 until the display shows 18.5° to 18.7° C.
7. Turn the calibrator output off.
8. Disconnect the calibrator from the multimeter.

DC Milliamperes

Perform the following steps to adjust the DC milliamperes calibration.

1. Set the multimeter dial to mA $\bar{\infty}$.
2. Connect the outputs of the calibrator to the μ A mA and COM input connectors of the multimeter.
3. Set calibrator to output 100.0 mA.
4. Press and hold the gold button for five seconds. (The multimeter beeps twice when the gold button is first pressed and then two more beeps follow after five seconds.)
5. Press the SETUP button and wait for the calibration to finish (CAL is displayed during the calibration). After the calibration is completed, press EXIT SETUP (blue button).
6. Turn the calibrator output off.
7. Disconnect the calibrator from the multimeter.

DC Amperes

Perform the following steps to adjust the DC amperes calibration.

1. Set the multimeter dial to A $\bar{\infty}$.
2. Connect the calibrator outputs to the multimeter A and COM inputs.

3. Set calibrator to output 10.00 A.
4. Press and hold the gold button for five seconds. (The multimeter beeps twice when the gold button is first pressed and then two more beeps follow after five seconds.)
5. Press the SETUP button and wait for the calibration to finish (CAL is displayed during the calibration). After the calibration is completed, press EXIT SETUP (blue button).
6. Turn the calibrator output off.
7. Disconnect the calibrator from the multimeter.

Adjustments Part 2

To perform the following procedure, you must lift out the entire circuit board assembly from the top case half to access the adjustments. Perform this procedure only if the *Performance Verification* procedure indicates that the AC voltage accuracy checks above 60 Hz is out of specification.

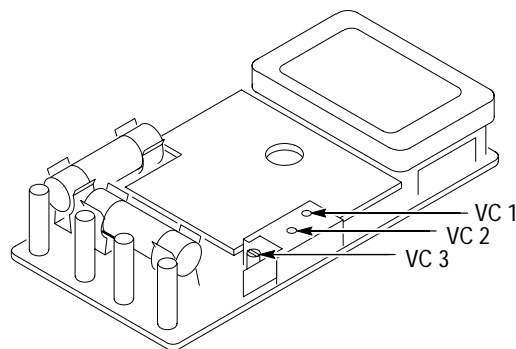

Figure 4: Adjustment locations 2

AC Response

Perform the following steps to adjust the AC voltage calibration above 60 Hz.

1. Set the multimeter dial to $V\sim$.
2. Lift the circuit board assembly out of the top case half.
3. Connect the outputs of the calibrator to the $\text{V}\ \Omega\ \text{Hz}$ and COM input connectors of the multimeter.
4. Set calibrator to output 100 VAC at 10 kHz (sinewave).
5. Adjust VC3 until the display shows +98.60 V.

6. Set the calibrator frequency to 500 Hz (sinewave).
7. Confirm that the reading is less than 100.60 V. Repeat step 5 if necessary.
8. Set the calibrator frequency to 1 kHz (sinewave).
9. Confirm that the reading is less than 104.0 V. Repeat step 5 if necessary.

NOTE. Steps 10 through 17 do not apply to the DMM912.

10. Set the calibrator to output 20 VAC at 10 kHz (sinewave).
11. Adjust VC1 until the display shows 19.700 V.
12. Set the calibrator frequency to 500 Hz (sinewave).
13. Confirm that the reading is less than 20.110 V. Repeat step 11 if necessary.
14. Set the calibrator to output 2 VAC at 10 kHz (sinewave).
15. Adjust VC2 until the display shows 1.9700 V.
16. Set the calibrator frequency to 500 Hz (sinewave).
17. Confirm that the reading is less than 2.011 V. Repeat step 15 if necessary.
18. Turn the calibrator output off.
19. Disconnect the calibrator from the multimeter.

Reassembling the Multimeter

1. Ensure that the rotary dial is properly aligned.
2. Align the tabs of the bottom case half with the slots in the top case half at the end of the meter near the input connectors.



CAUTION. Before closing the case, check that the rotary dial is properly aligned and that the battery wires are not pinched.

3. Close the case, snapping the case halves together.
4. Reinstall the three screws.